

T O U G H S T U F F !

Slant/Fin HD Series Heavy duty 16-gauge, slope top baseboard heating.

**Ideal for sites where rugged
treatment is anticipated.**

- 16-gauge steel front cover, 20-gauge back panel.
- Alternating element guide brackets and cabinet spacer brackets spot welded to back panel every 12 inches. Provides rigid support to resist impact damage.
- Cover secured by screws every 12 inches.
- Choice of 5 heating elements.

Slant/Fin[®]

HD Series Heavy Duty Baseboard

High strength. Low life cycle cost.

The extraordinary strength of HD Series baseboard makes it ideal for installation in sites where rugged treatment is anticipated. HD Series is especially recommended for schools, institutions and public housing. Its compact size and high output make it suitable for a wide range of new and retrofit applications. Among the design features giving HD Series its extraordinary strength are: heavy gauge enclosure including 16-gauge front cover, high strength support brackets welded to the back panel, screws that fasten the front cover directly to support brackets every 12 inches. HD Series' high strength and durability reduce maintenance and extend the life of the installation, providing a very low life cycle cost.

Hot water or steam. Preassembled.

A choice of five heating elements provides a range of output and capacity to closely match HD Series baseboard to job requirements. 1" and 1 $\frac{1}{4}$ " copper/aluminum elements permit higher flow rates, longer series-loop runs and lower pump loads where required. With the 1 $\frac{1}{4}$ " all-steel element, HD Series is ideal for use in one or two pipe steam systems. HD Series is factory pre-assembled in individual cartons for rapid installations.

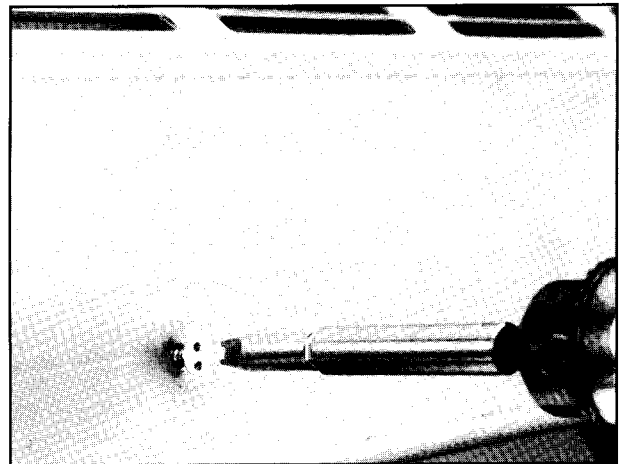
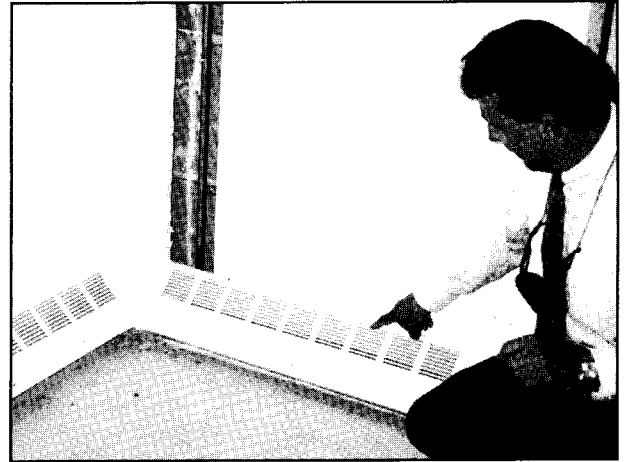

Optional tamper proof self-tapping screws secure the cover in place at each bracket location.

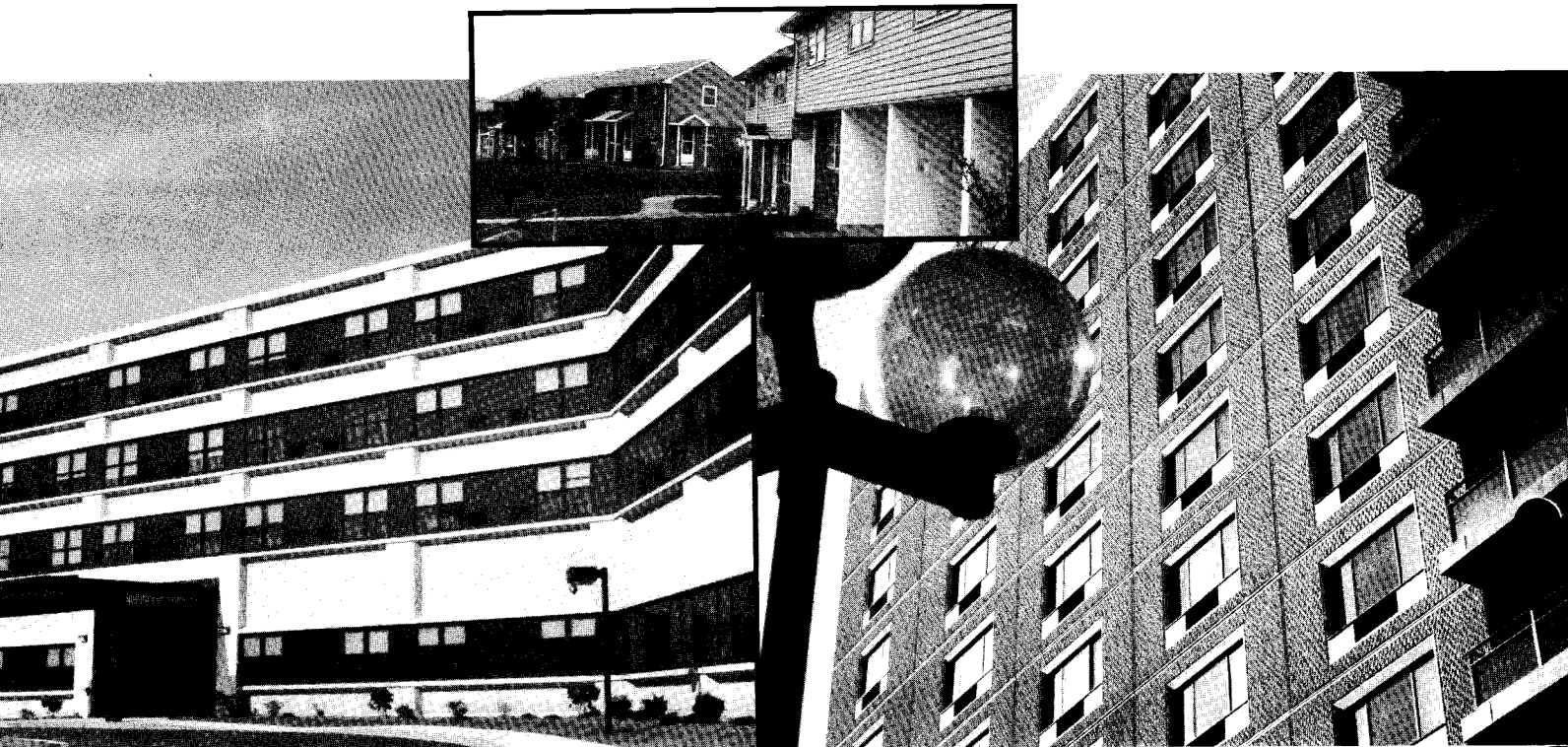

ACCESSORIES

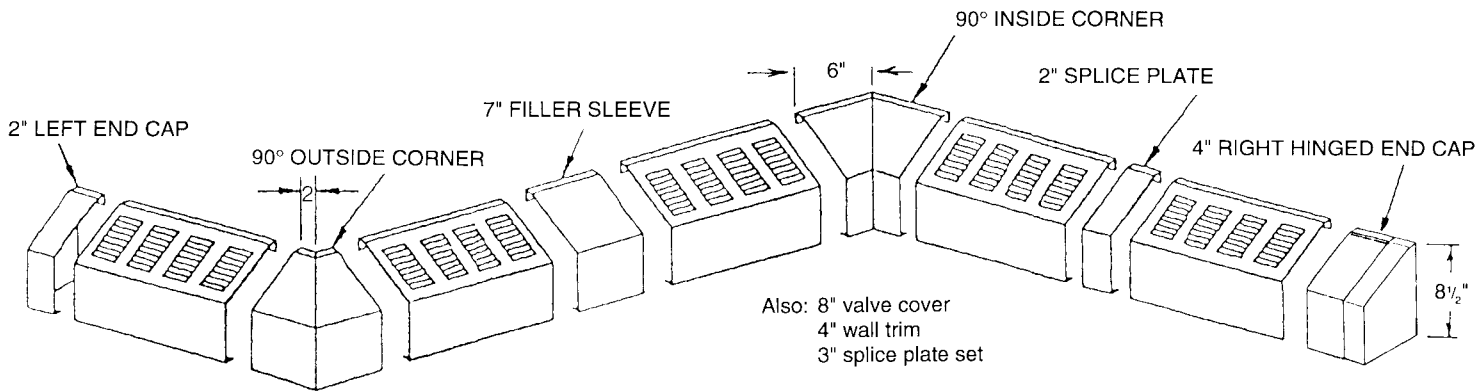

DIMENSIONS

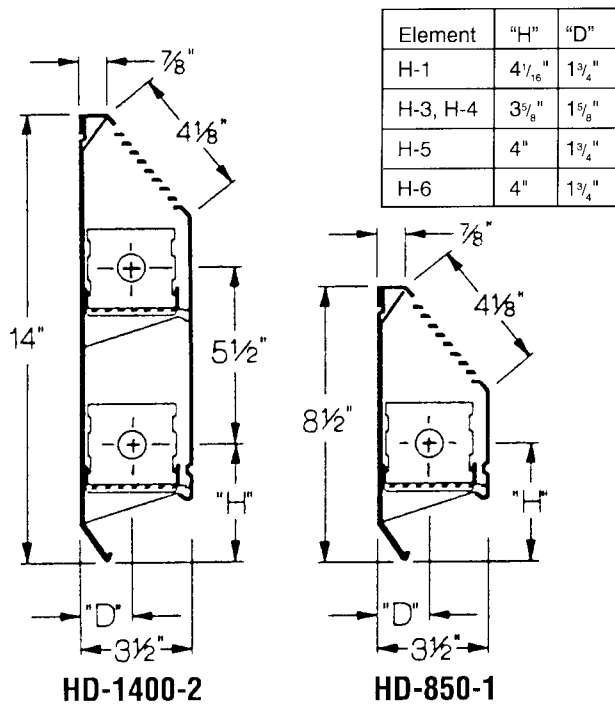

ORDERING DATA

HD SERIES

Complete Enclosure Assembly

PACKAGING: Complete two-piece enclosure assembly factory packaged with necessary brackets and hangers. Order element separately.

CONSTRUCTION: Full back panel with interlocking slope top front panel. Pencil-proof louvers. Bracket with element guide spot welded to back panel every 24 inches alternating with cabinet spacer welded to back panel every 24 inches giving rigid support to front every 12 inches. There are dimpled anchoring holes every 12 inches. For fastening front to brackets, use 8 x 3/8 self tapping screws with counter-sunk head as supplied by others. Stainless steel tamper proof screws optional.

DEPTH: 3 1/2"

HEIGHTS: 8 1/2" (one tier), 14" (one or two tier)

LENGTHS: 2', 3', 3 1/2', 4', 5', 6', 7' 8'.

Other 1/2' lengths available to order.

MATERIAL: 16-gauge steel front cover, 20-gauge back panel.

FINISH: Electro galvanized is standard. Available in custom color baked enamel finish.

ELEMENTS: Choice of five elements. Copper with aluminum fins: H-1, H-3, H-4, H-5. Steel with aluminized steel fins: H-6. Lengths from 2 to 8 feet.

JOINTS: Telescopic cover accessories eliminate the need to perfectly butt one length of cover to the next, reducing need for field cutting. Critical linear and vertical tolerances are eliminated because telescopic assembly absorbs misalignment that might result from uneven floors and walls.

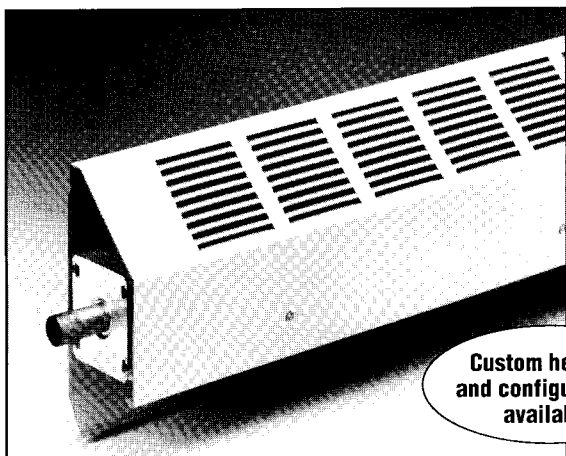

Custom heights
and configurations
available

HD Series Heavy Duty Baseboard

RATINGS

Model Number	Element Type	Rows of Heating Element	Tube Size & Material	Fin Size and Material	Fins Per Foot	Water Flow	Pressure Drop †	Steam 1 PSI Btu/Hr. Per Foot	HOT WATER RATINGS* BTU/HR./FT.							
									220°F 104°C	210°F 99°C	200°F 93°C	190°F 88°C	180°F 82°C	170°F 77°C	160°F 71°C	150°F 66°C
HD-850‡	H-1	1	3/4" copper	3 1/4" x 3" x .024" aluminum	48	1 GPM 4 GPM	47 525	—	1050 1110	970 1030	890 940	800 850	720 760	640 680	550 580	470 500
HD-850‡	H-3	1	3/4" copper	2 1/2" x 2 1/4" x .011" aluminum	55	1 GPM 4 GPM	47 525	—	940 990	870 920	790 840	720 760	640 680	570 600	490 520	420 440
HD-850	H-4	1	1" copper	3 5/32" x 2 1/2" x .011" aluminum	48	1 GPM 4 GPM	13 145	—	1030 980	860 1000	780 830	710 750	630 670	560 590	460 500	410 430
HD-850	H-5	1	1 1/4" copper	3" x 3 3/4" x .020" aluminum	48	1 GPM 4 GPM	6 63	1160	1010 1070	920 980	860 880	770 810	680 710	600 640	550 560	430 460
HD-850	H-6	1	1 1/4" IPS steel	3" x 3 3/4" x .025" aluminum	48	1 GPM 4 GPM	3 41	980	850 900	780 830	710 750	640 680	570 600	510 540	440 450	360 370
HD-1400‡	H-1	2	3/4" copper	3 1/4" x 3" x .024" aluminum	48	1 GPM 4 GPM	47 525	—	1570 1660	1450 1530	1320 1400	1190 1260	1070 1130	940 990	820 870	690 730
HD-1400‡	H-3	2	3/4" copper	2 1/2" x 2 1/4" x .011" aluminum	55	1 GPM 4 GPM	47 525	—	1460 1540	1340 1420	1230 1300	1110 1170	1000 1060	880 930	770 810	650 690
HD-1400	H-4	2	1" copper	3 5/32" x 2 1/2" x .011" aluminum	48	1 GPM 4 GPM	13 145	--	1440 1480	1330 1400	1220 1290	1100 1160	990 1050	870 920	740 790	640 680
HD-1400	H-5	2	1 1/4" copper	3" x 3 3/4" x .020" aluminum	48	1 GPM 4 GPM	6 63	1630	1530 1620	1400 1480	1290 1340	1160 1220	1030 1080	900 950	820 850	650 690
HD-1400	H-6	2	1 1/4" IPS steel	3" x 3 3/4" x .025" aluminum	48	1 GPM 4 GPM	3 41	1440	1370 1450	1260 1330	1140 1210	1030 1090	920 970	810 850	710 740	580 600

* Based on 65°F entering air temperature.

† Millinches per foot.

‡ I=B=R listed ratings.

Note: Ratings are based on active finned length (3" less than overall length), and include 15% heating effect factor.

Use 4 GPM ratings only when flow is known to be equal to or greater than 4 GPM; otherwise 1 GPM ratings must be used.

SPECIFICATIONS

HD Series

Furnish and install as shown on the plans HD Series—slope-top baseboard with element, required mounting components and accessories as manufactured by Slant/Fin Corporation. Complete two-piece enclosure assembly shall consist of full back panel with interlocking slope top front panel, factory packaged with necessary brackets.

Front cover shall be fabricated from 16-gauge steel, back panel from 20-gauge steel. The front panel & accessories shall be finished in hot dipped wiped coat galvanized finish or as custom color or matched as per specifications. Fin-tube element(s) shall be Model _____ . Provide lengths, heights and capacities as scheduled on plans.

Bracket with element guide shall be spot welded to back panel every 24 inches alternating with cabinet spacer welded to back panel every 24 inches giving rigid support to front every 12 inches. There are dimpled anchoring holes every 12 inches. For fastening front to brackets, use 8 x 3/8" self tapping screws with countersunk head as supplied by others. Tamper proof screws are available as an option.

Provide all required accessories for a complete installation. Cover accessories shall be telescopic to eliminate the need to perfectly butt one length of cover to the next.

H-1 Element

Furnish and install H-1 baseboard heating element as manufactured by Slant/Fin Corporation, consisting of 3/4" nominal copper tubing, with 3" x

3 1/4" x .024" aluminum fins, spaced 48 per linear foot. The tubing shall not be weakened by expansion in process of manufacture, but shall be forced through undersized fin holes to obtain a force-fit mechanical bond. A flange with four teeth shall be formed on each fin to increase thermal contact and to space and lock the fins uniformly in place. One end of each element tube shall be expanded to receive the unexpanded end of another, without couplings.

H-3 Element

Furnish and install H-3 baseboard heating element as manufactured by Slant/Fin Corporation, consisting of 3/4" nominal copper tubing, with 3 5/32" x 2 1/2" x .011" aluminum fins bent to 2 3/4" x 2 1/2", spaced 55 per linear foot. The tubing shall not be weakened by expansion in process of manufacture, but shall be forced through undersized fin holes to obtain a force-fit mechanical bond. A flange with four teeth shall be formed on each fin to increase thermal contact and to space and lock the fins uniformly in place. One end of each element tube shall be expanded to receive the unexpanded end of another, without couplings.

H-4 Element

Furnish and install H-4 baseboard heating element as manufactured by Slant/Fin Corporation, consisting of 1" nominal copper tubing, with 3 15/32" x 2 1/2" x .011" aluminum fins bent to 3" x 2 1/2", spaced 48 per linear foot. The tubing shall not be weakened by expansion in process of manufacture, but shall be forced through undersized fin holes to obtain a force-

fit mechanical bond. A flange with four teeth shall be formed on each fin to increase thermal contact and to space and lock the fins uniformly in place. One end of each element tube shall be expanded to receive the unexpanded end of another, without couplings.

H-5 Element

Furnish and install H-5 baseboard heating element as manufactured by Slant/Fin Corporation, consisting of 1 1/4" nominal copper tubing, with 3" x 3 1/4" x .020" aluminum fins, spaced 48 per linear foot. The tubing shall not be weakened by expansion in process of manufacture, but shall be forced through undersized fin holes to obtain a force-fit mechanical bond. A flange with four teeth shall be formed on each fin to increase thermal contact and to space and lock the fins uniformly in place. One end of each element tube shall be expanded to receive the unexpanded end of another, without couplings.

H-6 Element

Furnish and install H-6 baseboard heating element as manufactured by Slant/Fin Corporation, consisting of 1 1/4" IPS steel pipe (Schedule 40), with 3" x 3 1/4" x .025" steel fins, spaced 48 per linear foot. The pipe shall not be weakened by expansion in process of manufacture, but shall be forced through undersized fin holes to obtain a force-fit mechanical bond. A flange with four teeth shall be formed on each fin to increase thermal contact and to space and lock the fins uniformly in place. Both ends of each element pipe shall be threaded with IPS standard threads.

©Slant/Fin Corp. 1996. Printed in the U.S.A. 698. Publication No. HD-10.



SLANT/FIN CORPORATION, Greenvale, N.Y. 11548 • Phone: (516) 484-2600

FAX: (516) 484-5921 • Canada: Slant/Fin LTD/LTEE, Mississauga, Ontario

www.slantfin.com